



Efficient even in the toughest conditions

HUSKY
The Original Cool Ideas Co.



C Range undercounter chillers >>

HUS-C1HDA HUS-C2HDA HUS-C3HDA

Single, double, and triple door undercounter chillers

Features

- 1 Pressure injected foam insulation**
Maximum possible insulation ensures lowest possible energy wastage and significantly increases lifespan of compressor
- 2 Self closing doors** Minimize temperature disturbance and escape of cold air
- 3 Fan assisted cooling**
Ensures even temperature spread inside of the chiller and quicker pull down (cool down) times
- 4 Solid construction**
Ensures longer life under heavy usage
- 5 Integral locks fitted as standard**
Allows cabinet security when needed
- 6 Electronic temperature controller**
Defrosts automatically 6 times a day!
Ensures lower and more accurate temperature control between 35°F-50°F
Significantly improves use of energy
Longer compressor life
Digital temperature display
- 7 Full length double glazed glass door**
Devotes maximum area to display your high profit lines and ensures the ultimate in impulse sales
- 8 Fully adjustable shelves**
Provides the maximum number of merchandising options, irrespective of differences in pack sizes
- 9 Interior illumination**
Display contents to full effect
- 10 Pressure foamed with cyclopentane for ozone-friendly energy efficiency.**

R134a refrigerant Ozone-friendly

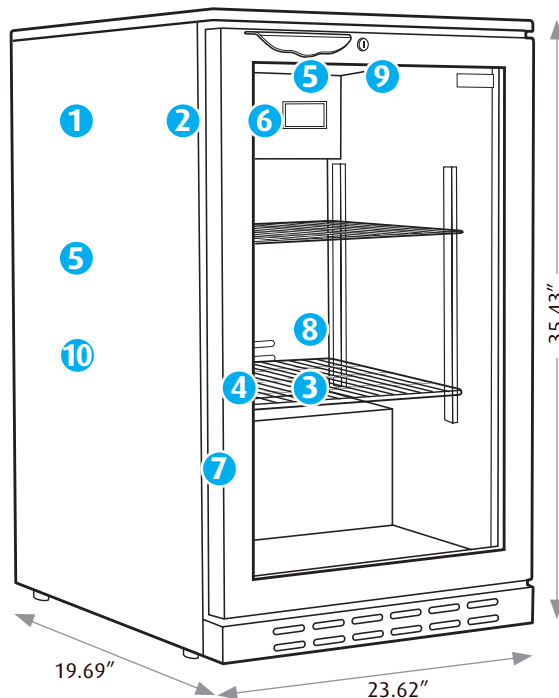

Note: Illustration shows model C1 specification.

The Husky back bar range offers huge advertising potential to the hospitality provider.

An attractive, well stocked and well lit glass-fronted cabinet, facing the customer, attracts attention and drives product interest, stimulating cold drink sales.

The C range of Husky back bar coolers optimizes the company concept of being "Good looking, efficient and reliable even in the toughest conditions".

Ultra-cold drinks are perfectly displayed in stylish cabinets with minimum running costs.

All coolers are ideal for use in bars, hotels, clubs, cafes and restaurants. All feature Husky quality at an affordable price.

Specifications



HUS-C1HDA single door undercounter chiller

External Dimensions: 35.43x23.62x19.69" (HxWxD)
Capacity: 4.59 cu.ft.
Weight: 106 lbs
Refrigerant: R134A
Shelves: 2
Air Cooling: Turbo air fan
Voltage: 110v/60Hz
Consumption: 1.3kWh/24h
Container Qty: 144
Approval: CE



HUS-C2HDA double door undercounter chiller

External Dimensions: 35.43x35.43x19.69" (HxWxD)
Capacity: 6.88 cu.ft.
Weight: 137 lbs
Refrigerant: R134A
Shelves: 4
Air Cooling: Turbo air fan
Voltage: 110v/60Hz
Consumption: 1.8kWh/24h
Container Qty: 100
Approval: CE



HUS-C3HDA triple door undercounter chiller

External Dimensions: 35.43x53.15x19.69" (HxWxD)
Capacity: 11.16 cu.ft.
Weight: 176 lbs
Refrigerant: R134A
Shelves: 6
Air Cooling: Turbo air fan
Voltage: 110v/60Hz
Consumption: 2.3kWh/24h
Container Qty: 66
Approval: CE

HUSKY
The Original Cool Ideas Co.

www.husky-group.com

Husky Direct Ltd.
The 4 Degree Centre
Bilton Way
Lutterworth LE17 4JA
United Kingdom
Tel: +44 (0)1455 555340
Fax: +44 (0)1455 555351
E-mail: info@husky-direct.com

Offices in USA, UK, China, Germany, Australia, South Africa, India, Ireland, and Venezuela.

Models shown for illustrative purposes only. Specifications may change without notice. It is the responsibility of the purchaser to confirm dimensions before ordering. Trademarks acknowledged to be property of their owners. E80E.



BRITISH FAMILY COMPANY SINCE 1957